

1600 t

RAUPENKRAN
CRAWLER CRANE
GRUE SUR CHENILLES

SWSL/LWSL - 85°

Arbeitsbereiche wippbarer Hilfsausleger mit Superlift, Hauptausleger 85°

Working ranges luffing fly jib with Superlift, main boom 85°

Portées fléchette à volée variable avec Superlift, flèche 85°

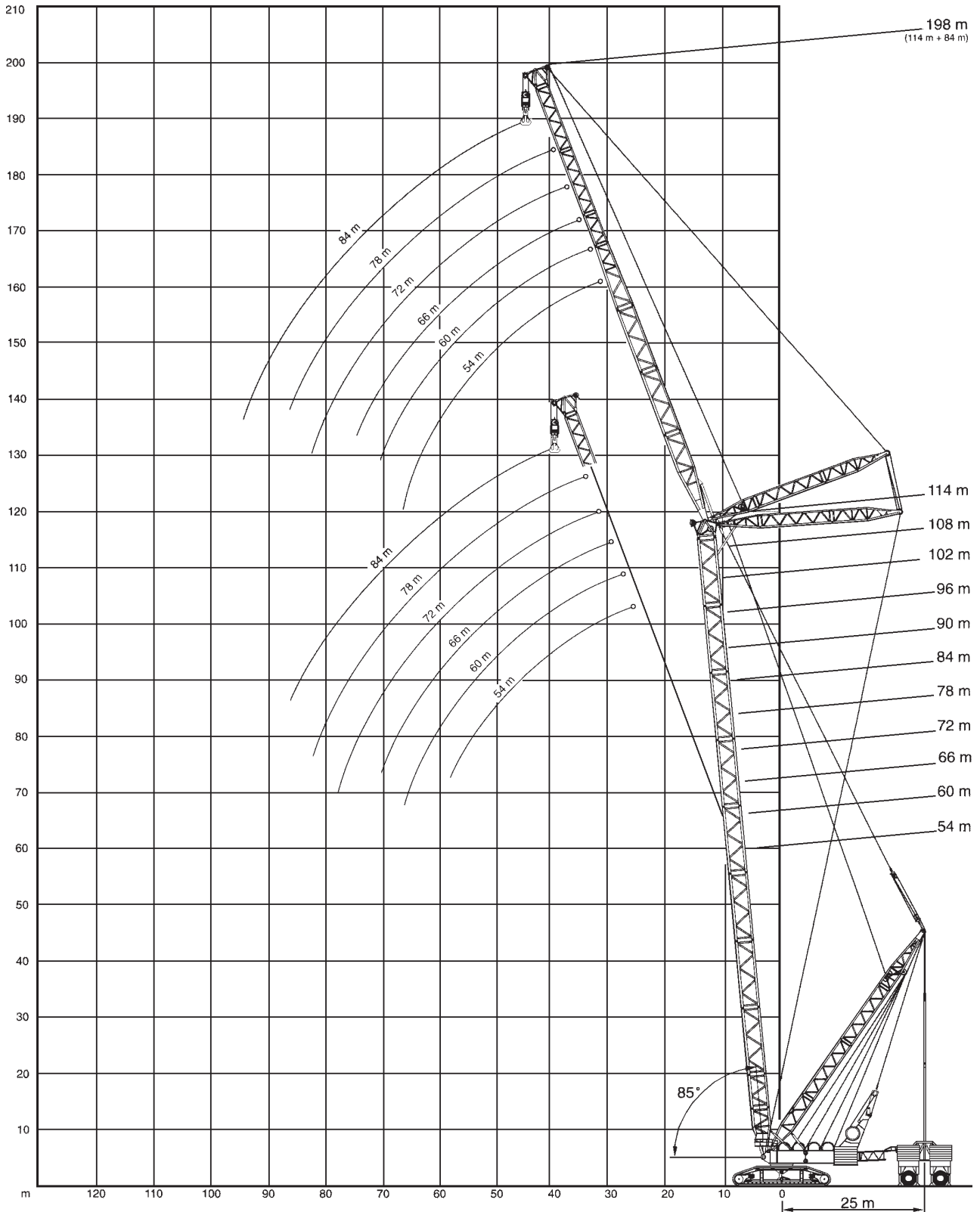

RAUPENKRAN

CRAWLER CRANE

GRUE SUR CHENILLES

1600 t

SWSL/LWSL - 85°

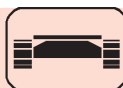
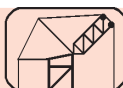
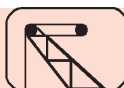

54-72m

48m

54-84m

1500t

12,2m

370t

360°

75%

m	54						60						m
	54	60	66	72	78	84	54	60	66	72	78	84	
28	800						800						28
30	800	789					800	731					30
34	755	747	693	640			772	687	632	585			34
38	681	700	658	613	526	455	725	654	603	563	495	443	38
42	597	625	616	571	493	424	647	625	572	531	467	416	42
46	508	547	550	519	459	394	565	564	539	491	437	389	46
50	421	484	486	462	425	364	497	498	500	447	406	362	50
54	341	432	434	407	390	336	425	445	447	401	375	335	54
58	274	378	391	356	357	308	359	388	402	357	346	309	58
62		325	349	315	324	283		335	353	319	318	284	62
66		270	305	278	294	260		281	302	283	292	262	66
70			260	244	267	240			259	248	269	242	70
74				208	243	222				213	247	224	74
78				172	222	206				178	228	208	78
82					204	191					209	193	82
86						178						180	86

m	66						72						m
	54	60	66	72	78	84	54	60	66	72	78	84	
30	766	674					703						30
34	725	641	597	555			672	597	545				34
38	686	614	573	539	483	430	638	569	524	489	446	404	38
42	645	589	551	515	459	408	601	545	504	470	426	385	42
46	580	561	528	485	433	384	558	522	483	447	405	364	46
50	509	511	499	451	405	359	508	495	459	422	381	342	50
54	437	455	458	414	377	334	437	458	431	394	357	320	54
58	370	398	411	375	349	309	371	398	397	364	333	298	58
62		344	359	337	323	286		343	358	332	310	277	62
66		291	308	300	300	264		290	317	298	289	256	66
70			267	263	278	244			276	264	269	238	70
74				226	258	226			229	229	250	220	74
78				189	239	210				195	233	205	78
82					217	195					215	191	82
86						182						179	86
90						169						167	90

1600 t

RAUPENKRAN
CRAWLER CRANE
GRUE SUR CHENILLES

SWSL/LWSL - 85°

Arbeitsbereiche wippbarer Hilfsausleger mit Superlift, Hauptausleger 85°

Working ranges luffing fly jib with Superlift, main boom 85°

Portées fléchette à volée variable avec Superlift, flèche 85°

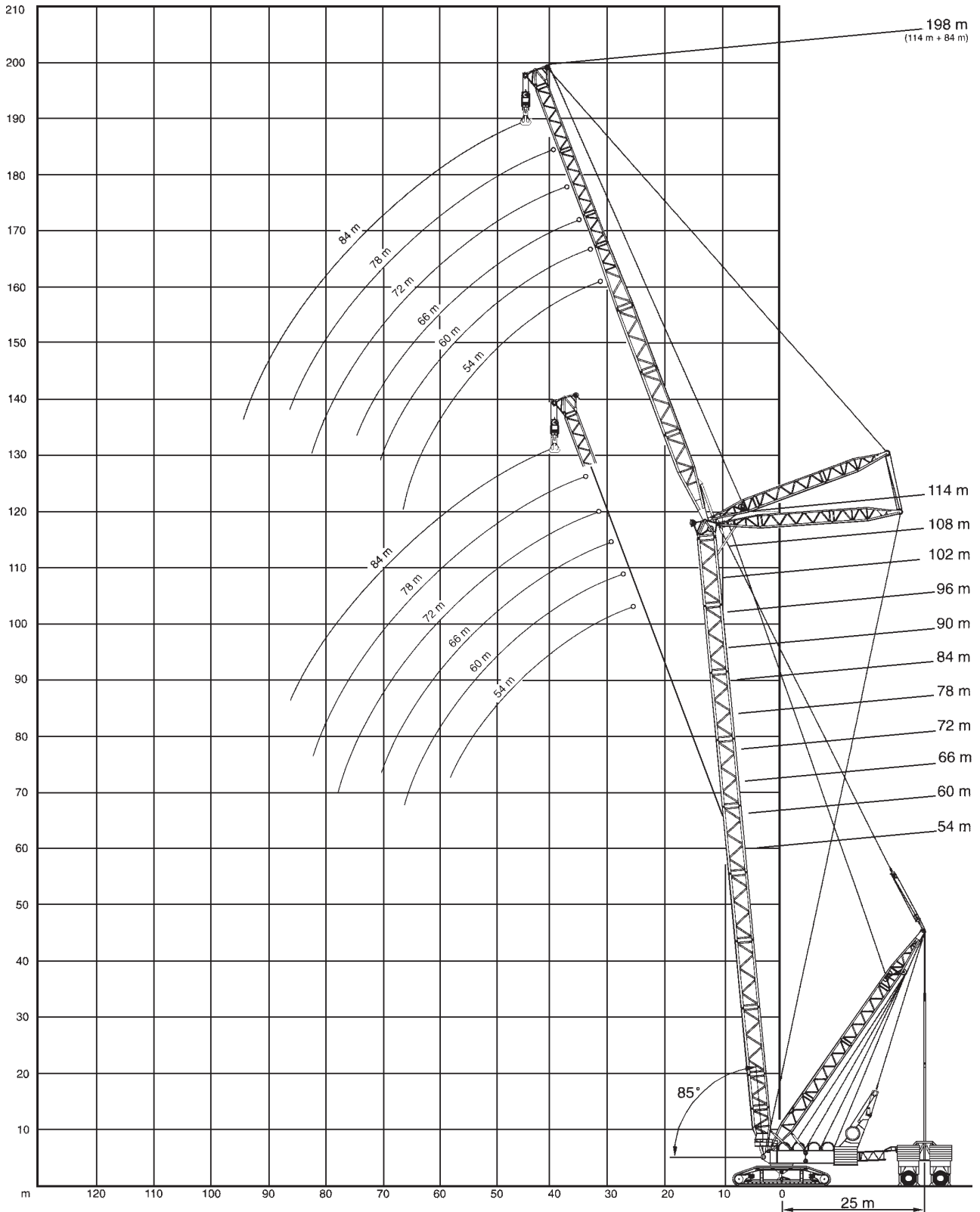

RAUPENKRAN

CRAWLER CRANE

GRUE SUR CHENILLES

1600 t

SWSL/LWSL - 85°

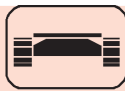
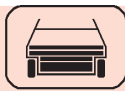
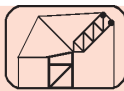
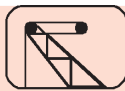
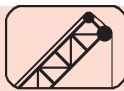

102-114m

48m

54-84m

1500t

12,2m

370t

360°

75%

m	102						108						m
	54	60	66	72	78	84	54	60	66	72	78	84	
34	431	397					387	354					34
38	421	383	352	322			376	343	312	288			38
42	407	369	340	315	295	276	364	332	303	280	260	248	42
46	389	356	328	307	287	270	350	321	294	272	254	248	46
50	368	342	316	298	278	263	334	309	284	262	247	242	50
54	344	326	305	288	268	254	316	297	274	252	241	235	54
58	317	309	293	277	258	243	295	283	265	242	234	227	58
62	288	288	282	264	248	232	270	268	257	230	226	218	62
66		263	270	249	238	220		251	248	218	218	208	66
70		238	255	232	229	208		234	238	206	209	198	70
74			237	213	219	197			225	194	199	188	74
78				191	210	187				181	188	178	78
82				169	199	176				168	175	168	82
86					188	167					161	159	86
90						157						151	90
94						145						143	94

m	114						m
	54	60	66	72	78	84	
34	335						34
38	324	316	288	258			38
42	312	306	280	251	240	220	42
46	301	296	271	245	234	220	46
50	291	286	263	239	228	220	50
54	278	275	254	232	222	215	54
58	256	262	245	226	215	207	58
62	216	248	237	218	209	198	62
66	176	231	228	208	202	189	66
70		214	219	197	194	180	70
74			210	183	186	170	74
78				166	177	159	78
82				149	168	149	82
86					157	137	86
90						126	90
94						115	94